

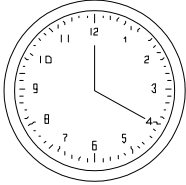

Imported by Amart Furniture Pty Ltd, Qld, Brisbane Australia.
for any assistance to assembly or for missing parts please phone
Amart Furniture, Customer Service Freecall 1800 351 084

PRE-ASSEMBLY PREPARATION

BEFORE YOU START :



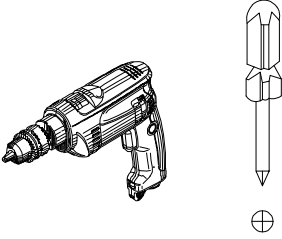

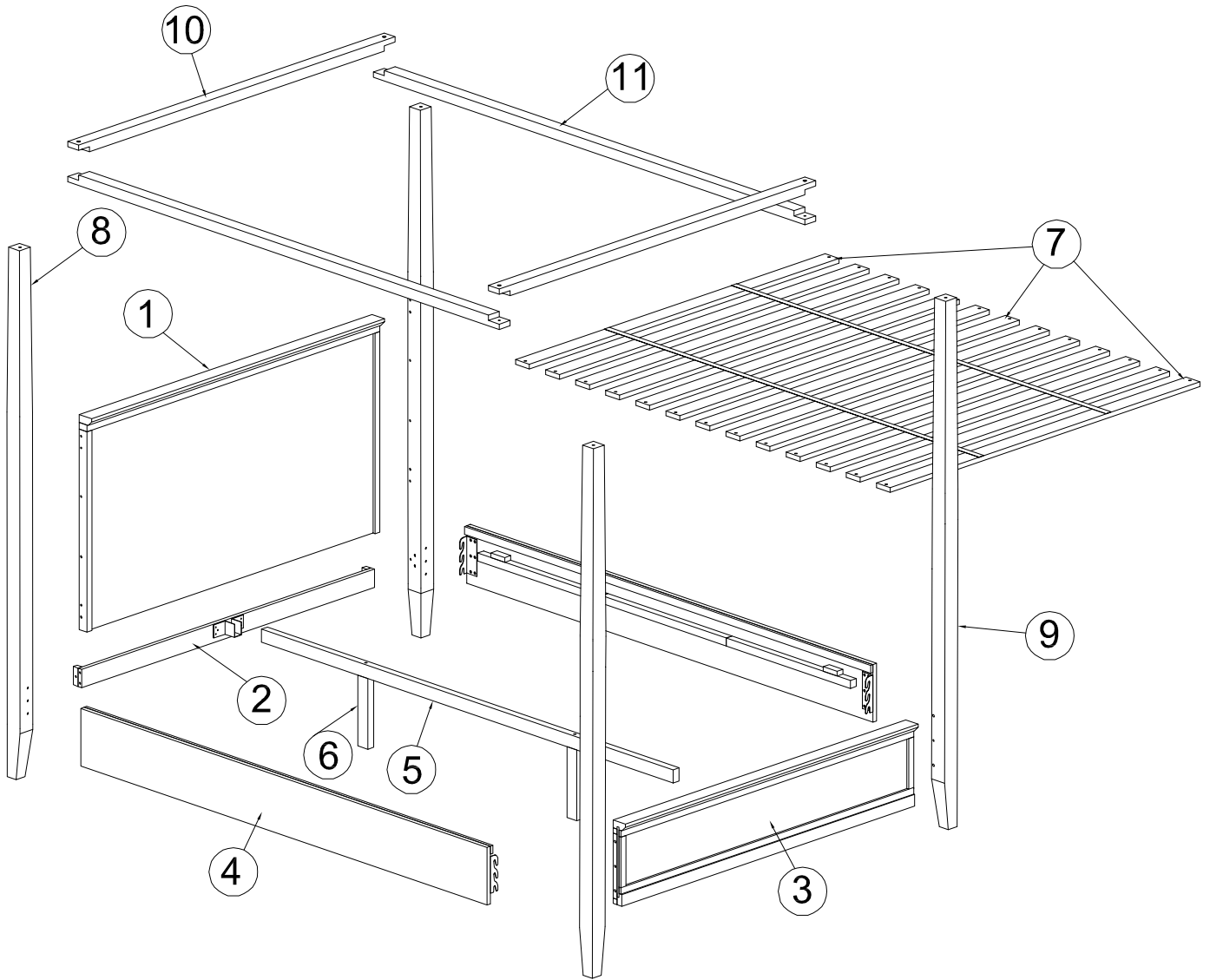

1. Choose a clean, level, spacious assembly area. Avoid hard surfaces that may damage the product
2. Take care when lifting. Product should be assembled as near as possible to the point of use
3. Ensure that you have all required contents for complete assembly
4. Always read the assembly instructions carefully before beginning assembly.
5. Keep all hardware parts and packaging out of reach of small children.
6. Do not over tighten the screws and bolts as this may damage the threads

	
ALLOW 20 MINUTES	2 PEOPLE REQUIRED
 <p>We recommend using screw driver to put this item together. However if you choose to use a power drill it must be used on LOW SPEED (LOW TORQUE) as too much pressure could damage the product.</p>	
ADDITIONAL TOOLS REQUIRED	

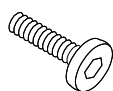
PARTS LIST

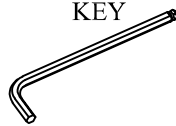
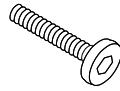

1	HEAD BOARD	1PC	7	SLAT	13PCS
2	STRETCHER	1PC	8	HB POST	2PCS
3	FOOTBOARD	1PC	9	FB POST	2PCS
4	SIDE RAIL	2PCS	10	SHORT CANOPY RAIL	2PCS
5	CENTER SUPPORT RAIL	1PC	11	LONG CANOPY RAIL	2PCS
6	SUPPORT LEG	2PCS			

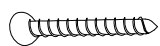
A. BOLTS  M6x50: 20PCS	B. SPRING WASHER  Ø6xØ12x1.2: 18PCS	C. FLAT WASHER  Ø6xØ19x2: 18PCS	D. DOWEL  Ø8x30: 14PCS	E. ALLEN KEY  M4: 1PC	F. BOLTS  M8x30: 12PCS
G. SPRING WASHER  Ø8xØ12x1.2: 12PCS	H. FLAT WASHER  Ø8xØ19x2: 12PCS	I. FLAT HEAD SCREW  Ø4x30: 29PCS			

Step 1: Insert Dowel (D) into Headboard (1) and Stretcher (2) to help align position of the Headboard (1) and Stretcher (2) on Posts (8). And then, using bolt (A), Spring washer (B), Flat washer (C) attach Posts (8) to Headboard (1) and Stretcher (2) using Allen key (E) to tighten.

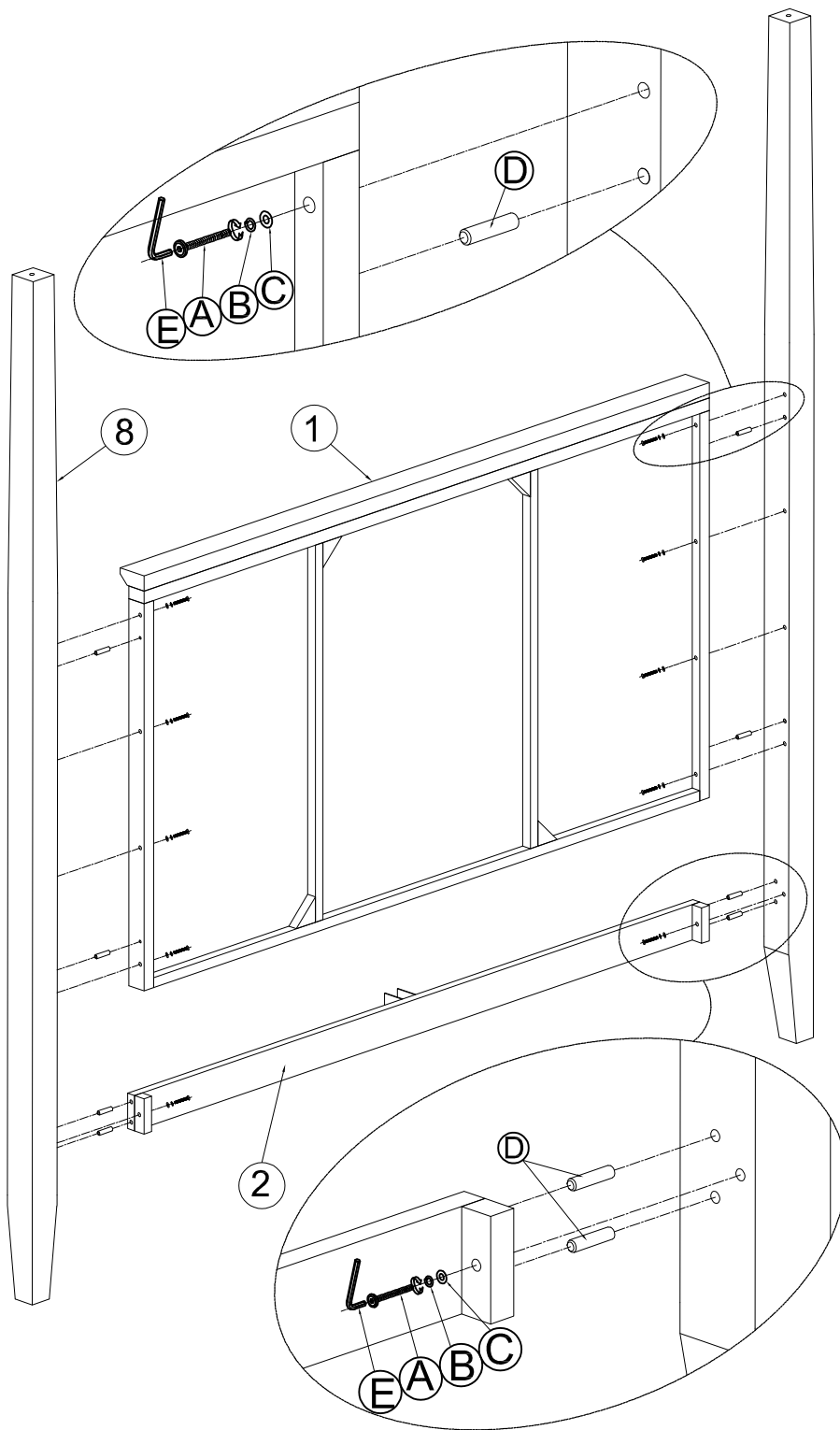

A. BOLTS

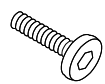

M6x50: 10PCS

B. SPRING WASHER



Ø6xØ12x1.2: 10PCS

C. FLAT WASHER



Ø6xØ19x2: 10PCS

D. DOWEL



Ø8x30: 8PCS

E. ALLEN KEY

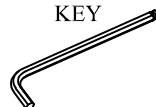

M4: 1PC

Step 2: Insert Dowel (D) into Footboard (3) to help align position of the Footboard on Posts (9). And then, using bolt (A), Spring washer (B), Flat washer (C) attach Posts (9) to Footboard (3) using Allen key (E) to tighten.

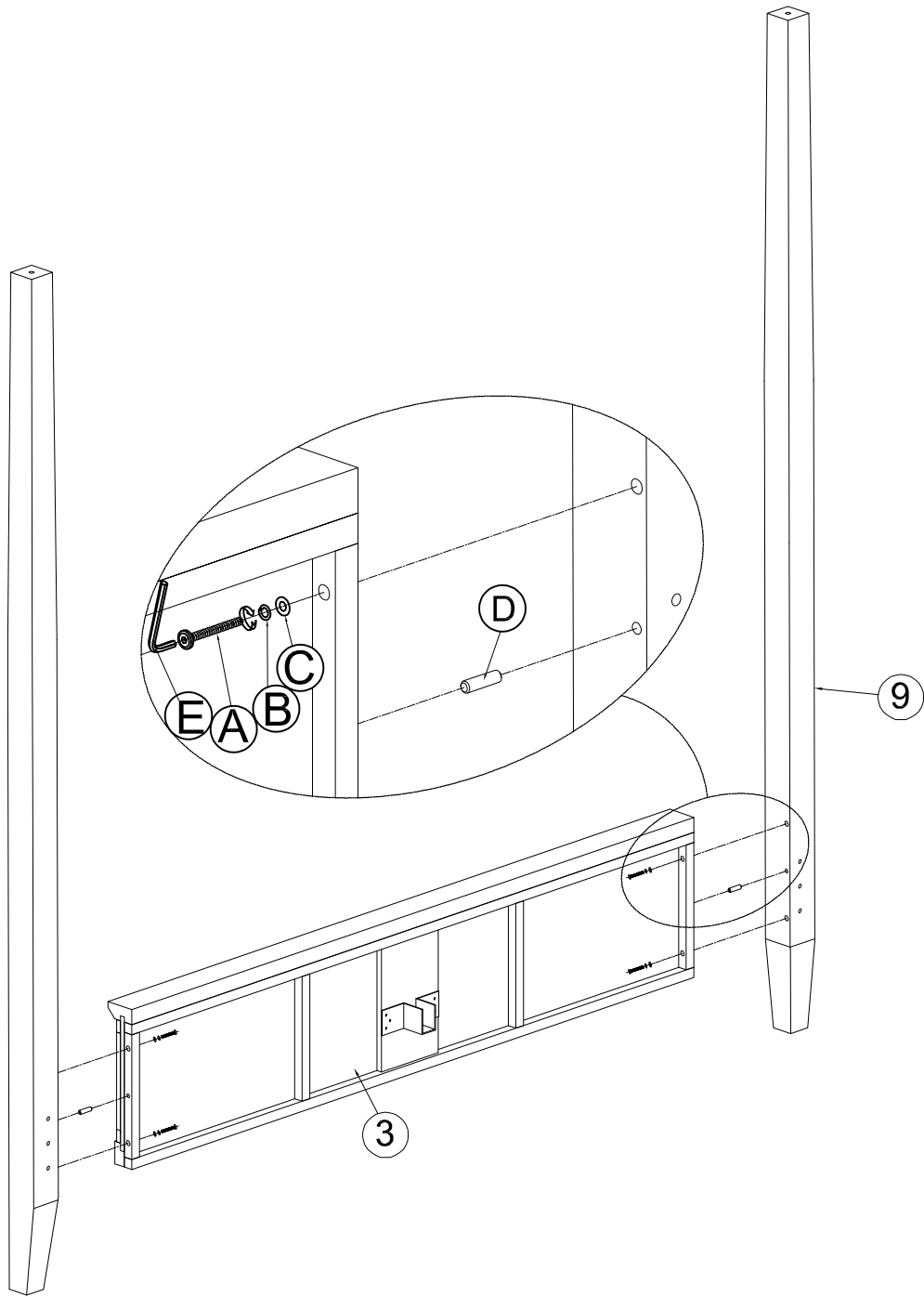

A. BOLTS

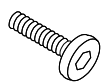

M6x50: 4PCS

B. SPRING WASHER



Ø6xØ12x1.2: 4PCS

C. FLAT WASHER



Ø6xØ19x2: 4PCS

D. DOWEL



Ø8x30: 2PCS

E. ALLEN KEY

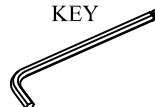

M4: 1PC

Step 3: Fasten the side rails (4) to the Headboard (1) and Footboard (3). Using Bolt (F), Spring washer (G) and Flat washer (H). Tighten with Allen key (E).

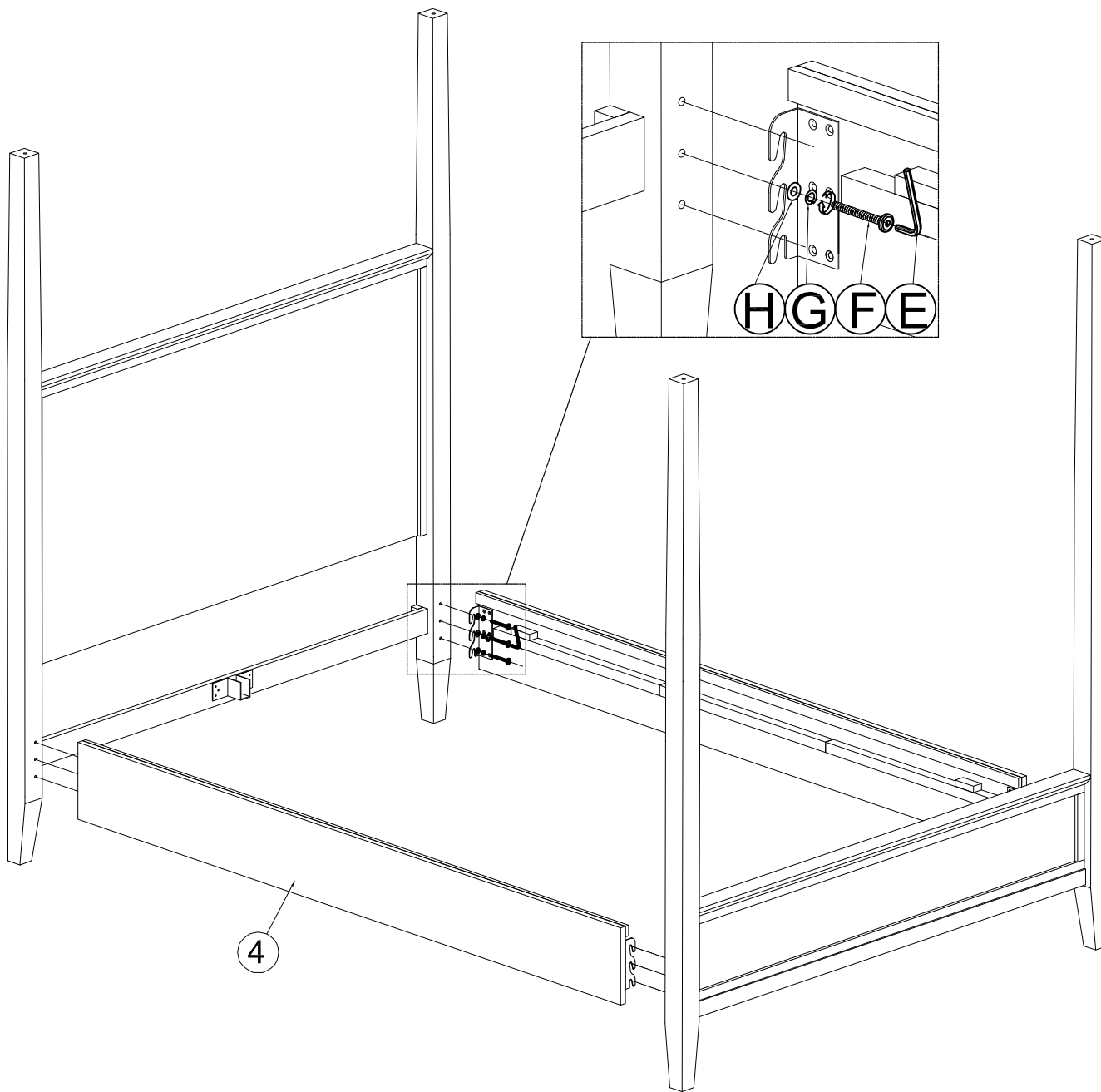

F. BOLTS

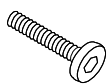

M8x30: 12PCS

G. SPRING WASHER



Ø8xØ12x1.2: 12PCS

H. FLAT WASHER



Ø8xØ19x2: 12PCS

E. ALLEN KEY

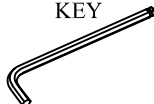

M4: 1PC

Step 4: Insert Dowel (D) into Support Leg (6). Using Bolts (A) attach the support legs (6) to the center support Rail (5). Tighten with Allen key (E).

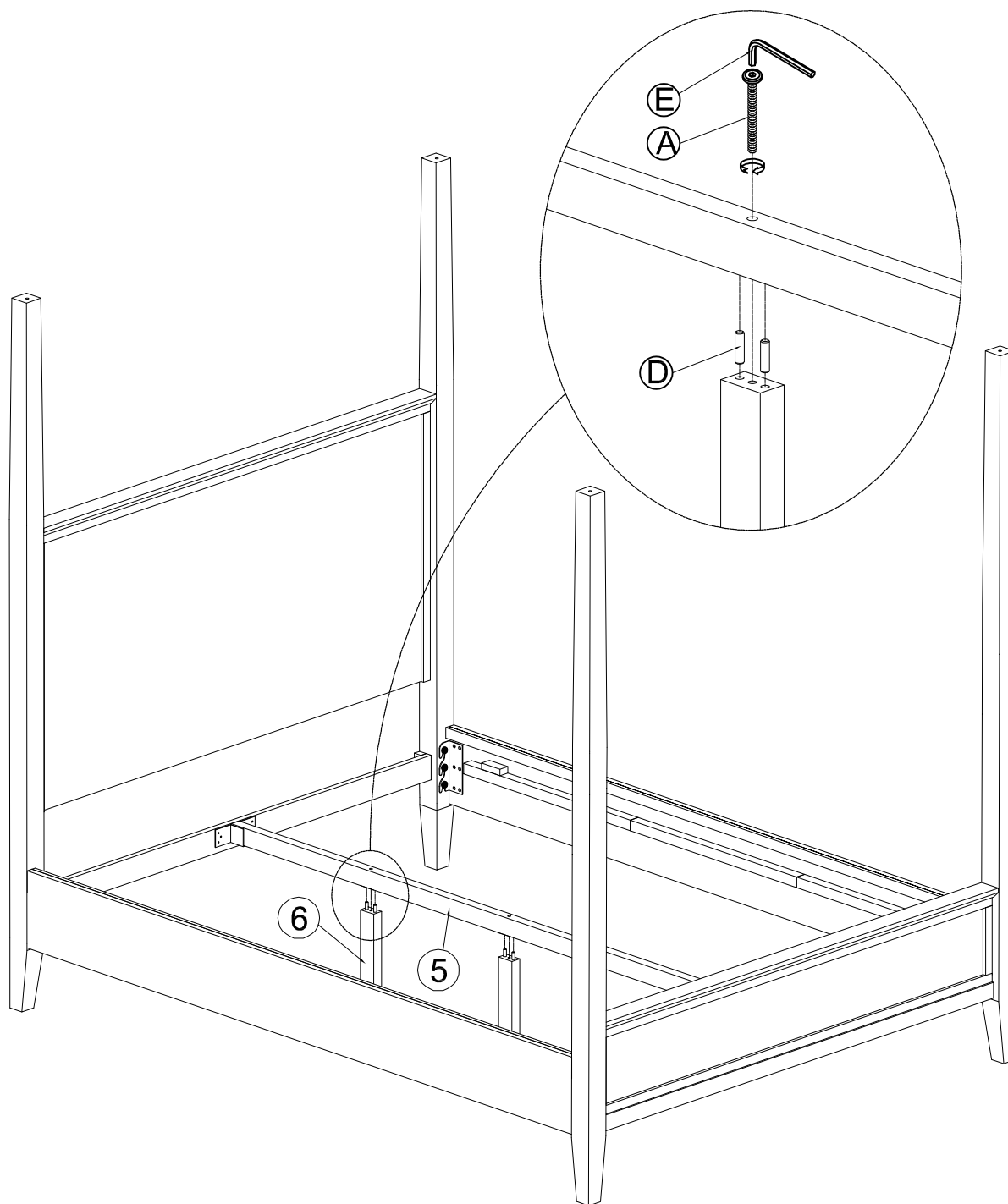

A. BOLTS



M6x50: 2PCS

D. DOWEL



Ø8x30: 4PCS

E. ALLEN
KEY

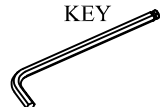

M4: 1PC

Step 5: Using screw (I), attach the slats (7) to the side rails (4). A screw is to be placed on each side of the slat, securing each slat to the side rail. The first, middle and end slat attach to the center support rail (5) using screw (I).

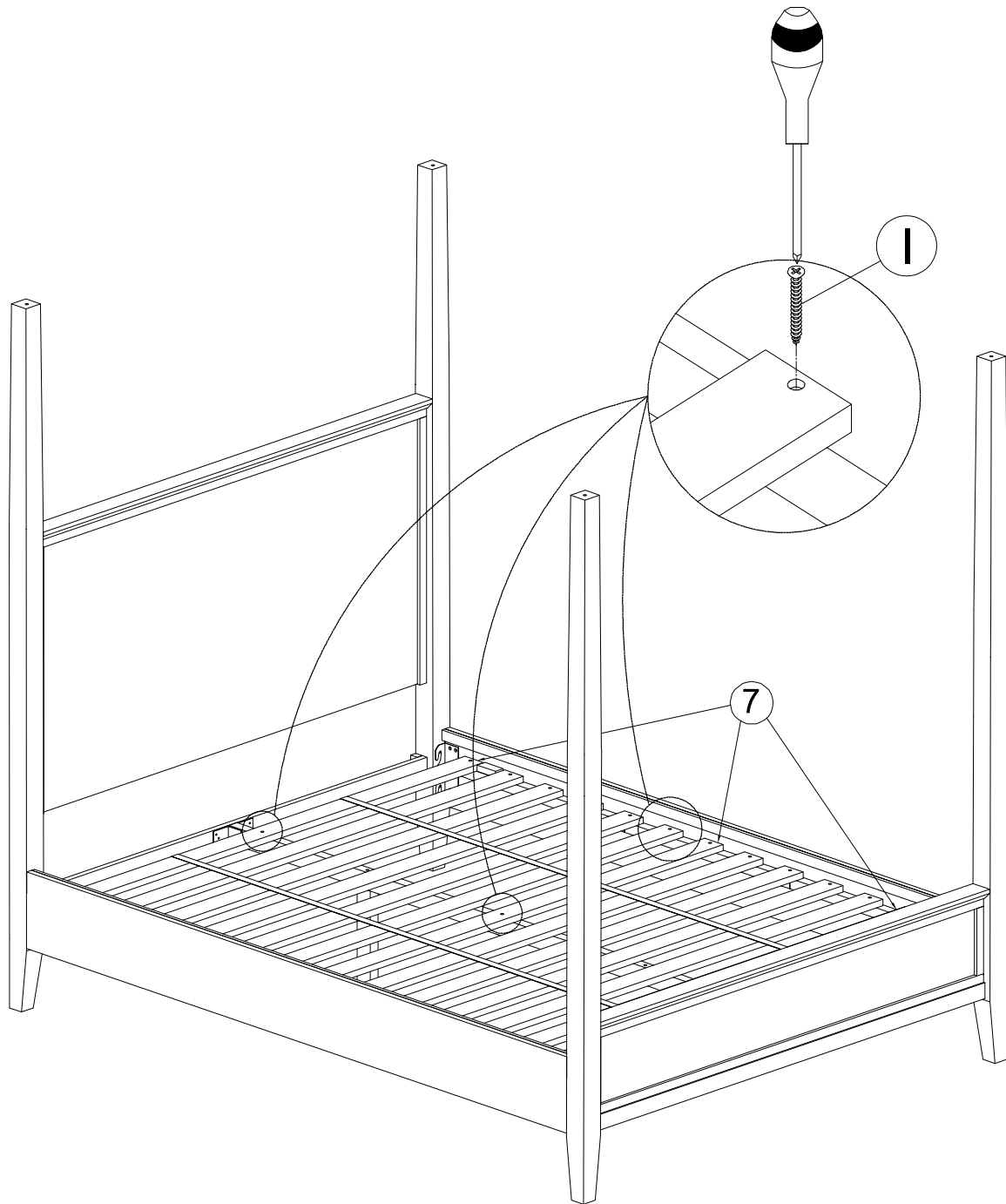

I. FLAT HEAD
SCREW

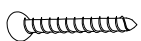

Ø4x30: 29PCS

Step 6: Place the long canopy rails (11) at top of posts between headboard and footboard first. And then, place the short canopy rails (10) upper to the long canopy rails at both ends (half-lap joints). Using Bolt (A), Spring washer (B), Flat washer (C) and tighten with Allen key (E).

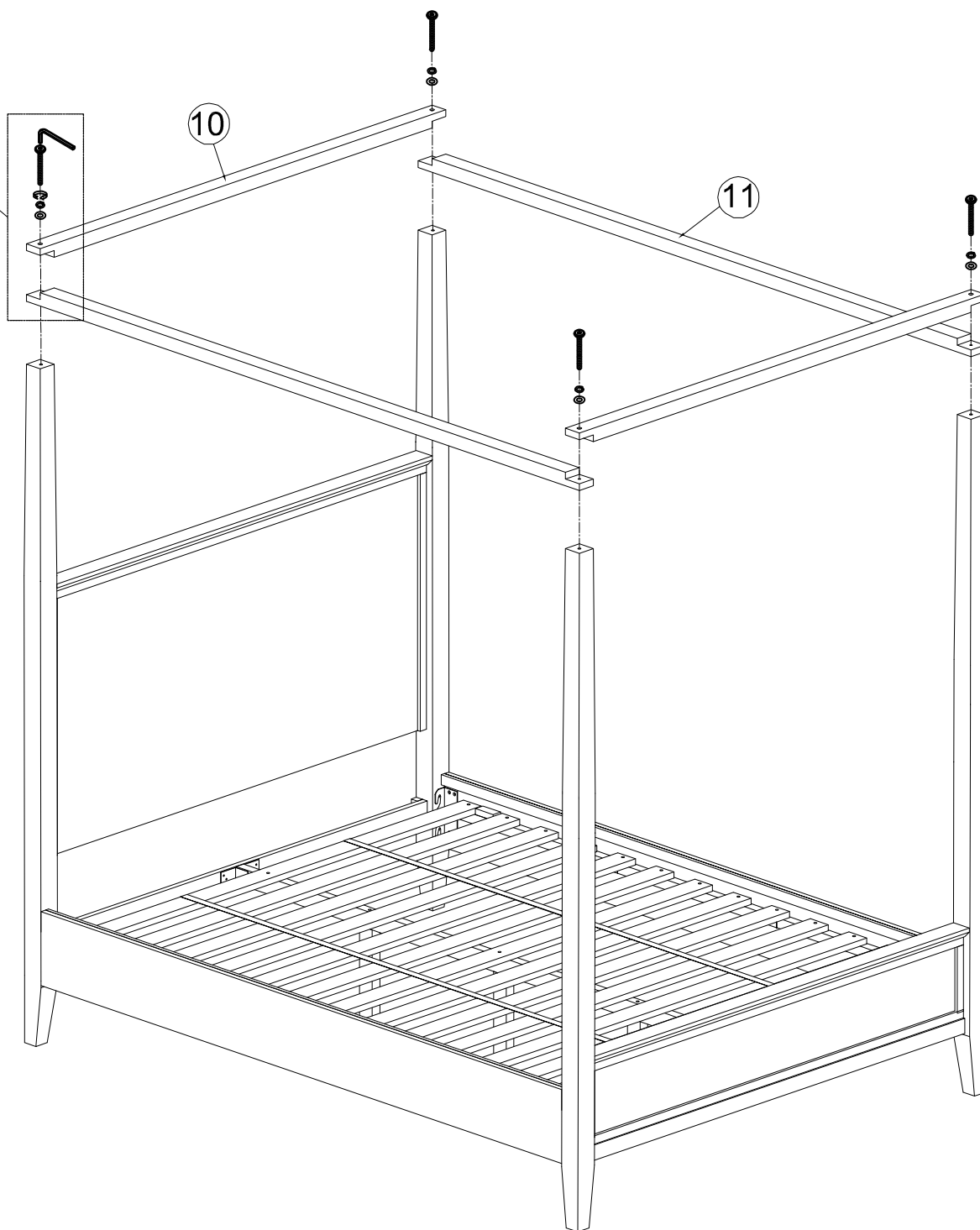
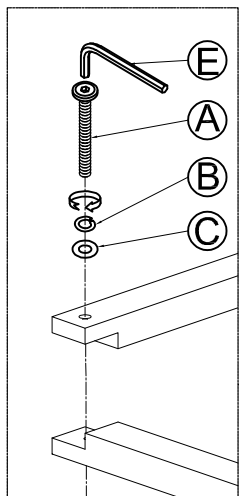

A. BOLTS



M6x50: 4PCS

B. SPRING
WASHER



Ø6xØ12x1.2: 4PCS

C. FLAT
WASHER



Ø6xØ19x2: 4PCS

E. ALLEN
KEY

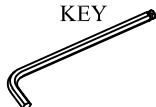

M4: 1PC

ASSEMBLY COMPLETE

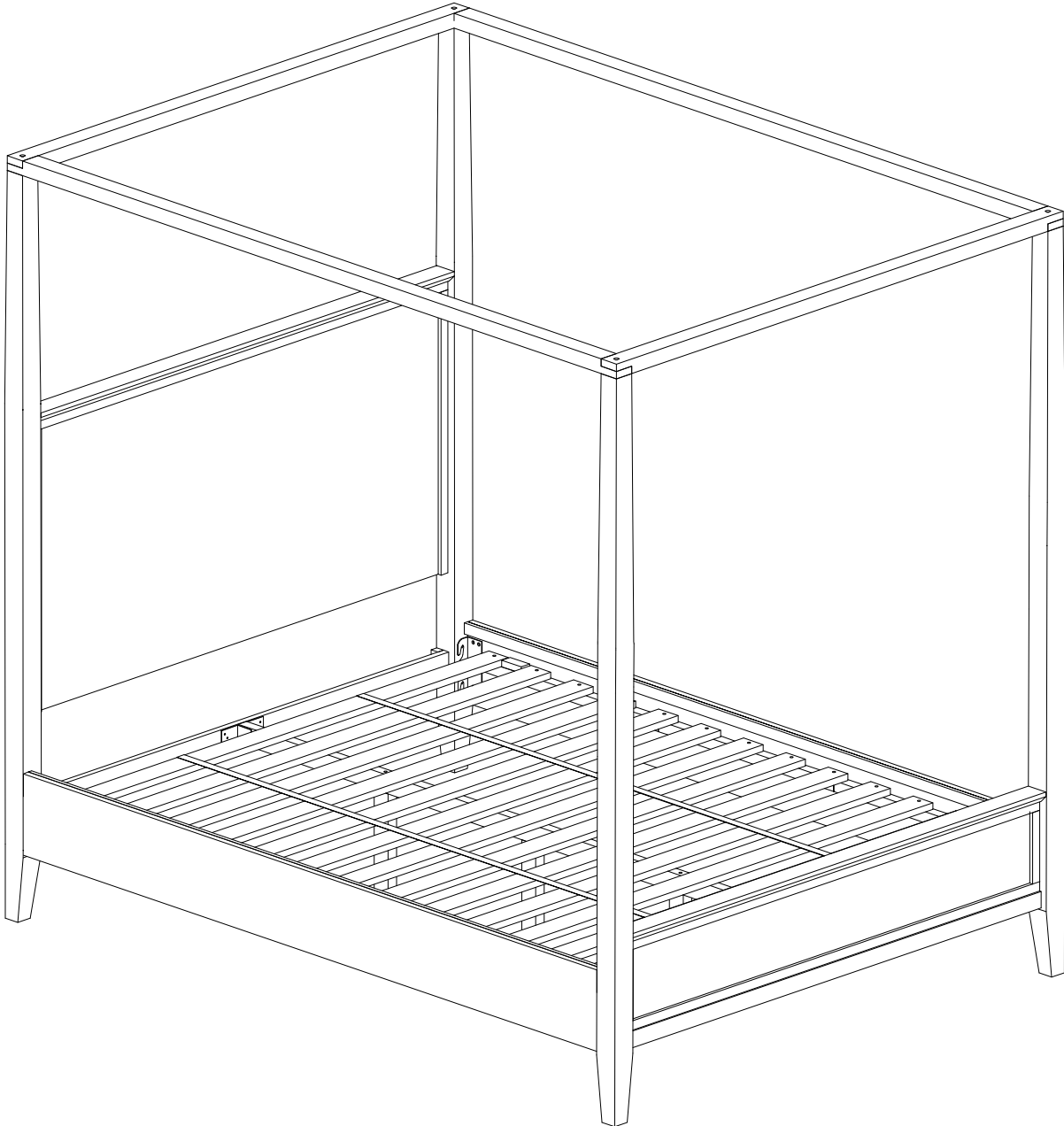

DO NOT PUSH OR DRAG THIS FURNITURE – IT WILL CAUSE DAMAGE TO THE LEGS



Product : **LOURDES 4 POST KING BED**

Item Code : **79225**

Product Care:

As your timber is supplied from sustainable forests there will be natural variations in surface texture and grain like knots, mineral streaks and sap runs that may affect the finish. These differences in character are not defects, but distinctions that make each piece of furniture unique. Our furniture is built to last. Following these steps for basic care should protect your investment for years to come.

- Dust frequently with a clean damp lint-free cloth. This will help remove abrasive build up which can damage a finish over time.
- Do not place hot objects on any furniture surface. Always use a hot plate or placemat. Laminate and lacquer finishes on table tops provide added scratch and heat resistance to our furniture, but they can still be damaged without proper care.
- Avoid exposing your furniture to strong sunlight, heat outlet, open windows or dampness. Prolonged exposure to direct sunlight can fade the finish of your furniture, while extreme temperature and humidity changes can cause cracking or splitting.
- Do not expose your furniture to any liquids. Never allow water to sit on your furniture. Alcohol, nail polish and perfume are also dangerous as they will dissolve the lacquer finish on contact and may require professional repairs.
- Do not allow plastic to come in direct contact with your furniture. Chemicals in the plastic of placemats etc may soften and mark the finish if left in contact with the furniture for a period of time.